

Europäisches Patentamt
European Patent Office
Office européen des brevets



(11)

EP 0 756 851 B1

(12)

EUROPEAN PATENT SPECIFICATION

(45) Date of publication and mention
of the grant of the patent:
28.06.2006 Bulletin 2006/26

(51) Int Cl.:
A61B 17/128 ^(2006.01) **A61B 17/00** ^(2006.01)

(21) Application number: **96112363.5**

(22) Date of filing: **31.07.1996**

(54) **Vascular hole closure**

Gefäßwundverschluss

Dispositif de fermeture d'une plaie vasculaire

(84) Designated Contracting States:
DE ES FR GB IT

(30) Priority: **03.08.1995 US 510834**

(43) Date of publication of application:
05.02.1997 Bulletin 1997/06

(73) Proprietor: **United States Surgical Corporation
Norwalk,
Connecticut 06856 (US)**

(72) Inventors:
• **Virnich, Patrick E.
Norwalk, CT 06850 (US)**
• **Castro, Salvatore
Seymour, CT 06483 (US)**

• **Marinkovich, Dragomir C.
Sandy Hook, CT 06482 (US)**

(74) Representative: **Marsh, Roy David et al
Hoffmann Eitle,
Patent- und Rechtsanwälte,
Arabellastrasse 4
81925 München (DE)**

(56) References cited:
EP-A- 0 324 549 EP-A- 0 637 431
EP-A- 0 656 191 WO-A-95/13021
US-A- 4 771 782 US-A- 4 929 240
US-A- 5 147 373 US-A- 5 207 691
US-A- 5 292 332

EP 0 756 851 B1

Note: Within nine months from the publication of the mention of the grant of the European patent, any person may give notice to the European Patent Office of opposition to the European patent granted. Notice of opposition shall be filed in a written reasoned statement. It shall not be deemed to have been filed until the opposition fee has been paid. (Art. 99(1) European Patent Convention).

Description

1. Technical Field

[0001] The present disclosure relates to an instrument and a hole or puncture in a blood vessel. More particularly, this disclosure relates to applying one or more clips to close a hole in a blood vessel after an intravascular catheterization procedure.

2. Background of Related Art

[0002] When performing catheterization procedures, such as angiography or angioplasty, a catheter is generally introduced into the vascular system by first penetrating the skin, underlying muscle tissue and blood vessel with a sharpened hollow needle. Next, a guide wire is commonly inserted through the lumen of the hollow needle and is caused to enter the selected blood vessel. Subsequently, the needle is typically stripped off the guide wire and a combination of a dilator and an introducer (or an introducer alone) are fed over the guide wire and pushed through the skin to enter the vessel. The guide wire can then be removed and the desired catheter to carry out the procedure is fed through the lumen of the introducer and advanced through the vascular system until the working end of the catheter is appropriately positioned. Following the conclusion of the catheterization procedure, the working catheter will be withdrawn and, subsequently, the dilator and/or introducer will also be removed from the wound.

[0003] At this point in the procedure, the vessel puncture must be sealed in order to stem the flow of blood through the puncture. Because it is common practice to administer a blood thinning agent to the patient prior to many of the catheterization procedures, stemming the blood flow can be troublesome. A common method of healing the wound is to maintain external pressure over the vessel until the puncture naturally seals. This method of puncture closure typically takes about thirty minutes, with the length of time usually being greater if the patient is hypertensive or anticoagulated. When human hand pressure is utilized, it can be uncomfortable for the patient and can use costly professional time on the part of the hospital staff. Other pressure techniques, such as pressure bandages, sandbags or clamps, have been employed, but these devices also require the patient to remain motionless for an extended period of time and the patient must be closely monitored to ensure their effectiveness.

[0004] Other devices have been disclosed which plug or otherwise provide an obstruction in the area of the puncture. See, for example, U.S. Patent Nos. 4,852,568 and 4,890,612, wherein a collagen plug is disposed in the blood vessel opening. When the plug is exposed to body fluids, it swells to create a block for the wound in the vessel wall. A potential problem of plugs introduced into the vessel is that particles may break off and float

downstream to the point where they may lodge in a smaller vessel, causing an infarct to occur. Collagen material also acts as a nidus for platelet aggregation and, therefore, can cause intraluminal deposition of hemostatic agent, thereby creating the possibility of a thrombosis at the puncture sight. Other plug-like devices are disclosed, for example, in U.S. Patent Nos. 5,342,393, 5,370,660 and 5,411,520.

[0005] Surgical clips and clip appliers are known have also been used in vascular surgery, particularly to join severed vessels. See, for example, U.S. Patent No. 4,929,240 (Kirsch, et al). The clips disclosed in the '240 Patent provide an advantage over suturing by decreasing the likelihood of clotting and vascular damage, particularly in micro-vascular repair procedures. While vascular clips have been successfully used in surgery, the surgical procedures in which the clips are used typically allow the surgeon to view the area to be clipped. In catheter puncture repair procedures, however, the wound is generally not visible, making proper clip application, if attempted, difficult.

[0006] Therefore, there is a need for surgical techniques suitable for closing punctures in blood vessels, particularly those created during catheterization procedures. This need requires a reliable hemostasis of the puncture in a quick and efficient manner. It would also be advantageous to close the puncture without disposing any foreign substances within the vessel, thereby preventing the likelihood of introducing foreign matter into the circulatory system. The technique also needs to be performed without directly viewing the punctured vessel.

[0007] EP 0 637 431 A1 describes an apparatus for suturing a perforation in a side wall of a patient's blood vessel. This apparatus includes an outer sheath having a longitudinal passage defined therethrough. The outer sheath is adapted to be inserted through the perforation in the patient's blood vessel. The apparatus further includes a suture point and a suture thread attached to the suture point. A carrier device is provided for carrying a suture point in a distal direction through the longitudinal passage of the outer sheath into the patient's blood vessel and for pulling the suture point in a proximal direction through the side wall of the patient's blood vessel.

SUMMARY

[0008] The present disclosure provides an instrument and method for closing a puncture in a blood vessel by applying at least one surgical clip to at least a portion of the exterior of the vessel. In a preferred embodiment, a guide wire passes extracorporeally through the skin, the vessel puncture, and into the blood vessel. A tubular structure, such as a cannula, is advanced over the guide wire and positioned near or adjacent the exterior of the blood vessel puncture. Next, a surgical clip applier is introduced into the cannula, preferably using the guide wire to guide the clip applier to the puncture sight. Once the distal end of the clip applier is properly positioned adja-

cent the vessel puncture, one or more surgical clips can be applied to close the puncture. Preferably, at least one clip is applied prior to removing the guide wire and at least one clip is applied subsequent to guide wire removal. After clip application, the clip applier and cannula can be removed and a topical bandage applied.

BRIEF DESCRIPTION OF THE DRAWINGS

[0009] Various embodiments are described herein with reference to the drawings, wherein:

Figure 1 is a perspective view of a preferred clip applying instrument;

Figure 2 is a side elevational view in partial cross section of the instrument of Figure 1;

Figure 3 is an exploded perspective view of the instrument of Figure 1;

Figure 3a is an enlarged perspective view of the distal, clip applying portion of the instrument of Figure 1;

Figure 3b is an enlarged perspective view of a clip suitable for use with the disclosed clip applier;

Figure 3c is a side elevational view of the clip of Figure 3b;

Figure 4 is a side elevational view in partial cross section of the instrument of Figure 1 prior to actuation;

Figure 5 is a side elevational view in partial cross section of the instrument of Figure 1 after actuation of the primary firing button;

Figure 6 is a side elevational view in partial cross section of the instrument of Figure 1 after actuation of the secondary firing button;

Figure 7 is a side elevational view in partial cross-section showing the instrument of Figure 1 being advanced towards a cannula using a guide wire as a guide;

Figure 8 is a side elevational view in partial cross-section showing the distal end of the instrument of Figure 1 disposed adjacent a blood vessel to be clipped;

Figure 9 is a side elevational view in partial cross-section, showing the instrument of Figure 1 applying one clip to a portion of the exterior of a blood vessel;

Figure 10 is a side elevational view in partial cross-section showing the removal of the guide wire prior

to application of additional surgical clips;

Figure 11 is a side elevational view in partial cross-section showing two clips being applied substantially simultaneously to the blood vessel; and

Figure 12 is a side elevational view in partial cross-section showing the clipped blood vessel after the clip applier of Figure 1 has been fired and withdrawn from the cannula.

DETAILED DESCRIPTION OF THE PREFERRED EMBODIMENTS

[0010] Referring now in specific detail to the drawings, in which like reference numerals identify similar or identical elements throughout several views, and initially to Figure 1, a preferred clip applying instrument 10 is shown. Instrument 10 has proximal handle portion 12, distal clip applying portion 14 and intermediate portion 15 disposed therebetween. As used herein, the proximal end of an element is referred to as the end of the element nearest to the surgeon and the distal end of an element is referred to as the element furthest from the surgeon.

[0011] Referring to Figs. 1-3 and 3a, the components of clip applying instrument 10 will be discussed in detail. Handle portion 12 has housing portions 16 and 18 which house primary firing button or actuator 20 and secondary firing button or actuator 22. Primary firing button 20 includes first cavity 24 having side slots 26a and 26b and second cavity 28 having a distally extending projection 30 disposed therein. Projection 30 serves to align and at least partially retain primary button spring 38 between primary firing button 20 and shelf 40, which projects inwardly from housing 18. Structure corresponding to shelf 40 (not shown) can be provided on the inside of housing portion 16 and be positioned to mate with shelf 40 when housing portions 16 and 18 are assembled. Spring 38 biases primary firing button 20 proximally. Also extending distally from button 20 are latching fingers 32a and 32b, each having protrusions 34a and 34b at their respective distal ends, the purpose of which will be discussed below. Between latching fingers 32a and 32b is firing channel engagement member 36.

[0012] Secondary firing button 22 has cavity 41 and distally extending projection 42 disposed therein. Projection 42 is similar to projection 30 in the primary firing button and is adapted to engage secondary button spring 44 which is disposed between projection 42 and shelf 46, which projects inwardly from housing 18. Spring 44 biases secondary firing button 22 proximally. Secondary firing button 22 has a pair of distally extending biasing fingers 48a and 48b. Between biasing fingers 48a and 48b is firing channel engagement member 50. Secondary firing button 22 is slidably received within cavity 24 of the primary firing button, wherein side projections 52a and 52b in the secondary button are slidably received in slots 26a and 26b of the primary button. Because button 20

can move relative to button 22, the distal clip applying structures are independently actuatable, as will be discussed in greater detail, below. When handle portion 12 is assembled, firing buttons 20 and 22 are nested between housing portions 16 and 18 and screws 54 and 56 serve to at least partially secure the assembly. Of course other means for securing the housing portions can be utilized, such as, for example, glue, welds, friction fittings and the like.

[0013] Firing buttons 20 and 22, as best shown in Figure 1, are positioned on the proximal most portion of the apparatus for accessibility to the user. To enable the user to readily differentiate between the buttons, primary firing button 20 has a substantially planar outer surface and secondary firing button 22 has a concave surface. Each of the buttons are configured to be pressed inwardly towards housing portions 16, 18 to fire the clips in the manner discussed below. Clearly, other actuator configurations in alternate locations are contemplated. For example, instead of having two firing buttons, a single firing button having different stages of firing along a common stroke path can be used. Also, for example, trigger mechanisms or gas-powered mechanisms can be provided as is known in the art.

[0014] Turning to the intermediate and distal portions of instrument 10, there are preferably two firing channels 62 and 64 which house clip bars 66 and 68, respectively. The proximal end portions of the firing channels have windows 70 and 72 which are configured to receive the distal ends of firing channel engagement members 36 and 50. Jaws 88 extend distally from clip bar 68 while jaws 90 and 92 extend distally from clip bar 66. When the clip bars are assembled within the firing channels, each set of jaws are disposed distal of the firing channel distal ends. Therefore, by depressing the firing buttons and causing the firing channels to move distally, the jaws are cammed inwardly, resulting in clip closure (discussed in greater detail below). The firing channels also have intermediate slots 74 and 76 which permit the channels to slide relative to pins 58 and 60 during operation. Clip bars 66 and 68 have apertures 78, 80, 82 and 84 to receive pins 58 and 60 therethrough to thereby mount the bars 66, 68 to housing portions 16, 18. During operation, pins 58 and 60 prevent distal/proximal movement of the clip bars while firing channels 62 and 64 slide thereover to fire clips. In the particular preferred embodiment shown in Fig. 3a, the distal end of clip bar 68 has a single pair of jaws 88 configured to retain and apply one surgical clip, while the distal end of clip bar 66 has two pairs of jaws, 90 and 92, each configured to retain and apply a surgical clip. Jaw 92, as shown, is preferably positioned on top of jaw 90 while jaw spacer 89 is provided to separate jaws 88 from jaws 90 and 92. Jaws 88, 90 and 92 are preferably disposed at a common angle with respect to the longitudinal axis of clip applicator 10.

[0015] Figure 3a also illustrates the distal end of firing channel 62 having tubular guide wire guide member 94 secured thereto. Guide member 94 is configured to receive

a guidewire to facilitate placement of the instrument at the desired surgical site and is preferably a hollow structure constructed from one or more pieces. In the drawings, guide member 94 is shown in two parts, part 94a being disposed along the firing channel and part 94b being positioned to over hang the jaw structure. Guide member 94 is preferably secured by welding, however, other suitable securement methods can be used. The function of guide 94 is discussed in greater detail below.

[0016] A preferred clip is shown in Figs. 3b and 3c. Surgical clip 242 is designed for application by clip applicator 10 and is formed of a unitary piece of biologically acceptable, plastically deformable material such as a noble metal (i.e., gold, silver, platinum, titanium, etc.). While metal clips are presently preferred, it is contemplated that other materials, such as suitable polymer plastics, can be used. The material, preferably titanium, is sufficiently ductile or plastically deformable so that when the clip is crimped, there is minimal spring-back. The clip is designed to apply constant force to tissue, regardless of tissue thickness, without penetration. However, clips that penetrate tissue can also be utilized.

[0017] Clip 242 includes a pair of inwardly curved arms 202 and 204 interconnected by a bridge portion 206. The two arms extend generally perpendicular to bridge portion 206 and terminate at tips 210 and 212 which are rounded to prevent injury to the subject tissue. The bridge portion 206 includes a pair of optional grooves 208 which are useful for receiving an advancing/pushing bar if an array of clips are to be stored and sequentially applied. Clip slots 91 (Fig. 3a) in jaws 88, 90 and 92 are configured to receive arms 202 and 204 of clips 242. The clip can be sized according to the particular end use, but it is generally a size suitable for micro-surgical applications in both non-endoscopic and endoscopic procedures.

[0018] The operation of instrument 10 is generally shown in Figs. 5-11. As shown in Figs. 5 and 9, the first clip is applied by depressing primary firing button 20, in the direction of Arrow A. Depression of button 20 causes firing channel 64 to slide distally (Arrow B) over stationary clip bar 68 (Fig. 3), causing jaws 88 to cam inwardly as the distal end of channel 64 contacts camming surface 93 of the jaws (Fig. 3a). As the jaws cam inwardly, the clip held therein (Arrow B') is formed. As shown in Fig. 5, secondary firing button 22 remains stationary as primary firing button 20 is depressed. When button 20 is completely depressed, protrusions 34a and 34b of latching fingers 32a and 32b catch on ledge member 96 in handle portion 12. When latched, button 20 and firing channel 64 are held in the distal position, thereby maintaining jaws 88 in the closed position. Turning to Figs. 6 and 11, jaws 90 and 92 are closed by depressing secondary firing button 22 (Arrow C) which causes firing channel to move distally (Arrow D) over stationary clip bar 66, further causing both jaws 90 and 92 to form the clips held therein (Arrow D') . At the distal end of travel of button 22, biasing fingers 48a and 48b contact latching fingers 32a and 32b and release the fingers from ledge

96, thereby freeing button 20. Upon release of pressure from button 22, springs 38 and 44 bias buttons 20 and 22, respectively, in the proximal direction. Proximal movement of the buttons also cause firing channels 62 and 64 to move proximally. With the firing channels in the proximal position, jaws 88, 90 and 92 resiliently spring open to release the deformed clips.

[0019] A preferred method of closing a hole in a blood vessel is shown in Figs. 7-11. Initially referring to Fig. 7, a blood vessel or artery 100, such as the femoral artery, is shown disposed below skin 102 of a patient. Vessel 100 is shown subsequent to a catheterization procedure, i.e., a puncture 106 has been created in vessel 100. Guide wire 104 passes through skin 102 and enters artery 100 at puncture sight 106. If the guide wire was removed during the catheterization procedure, it is preferably reinserted to perform the clipping procedure. Other structures for aiding in locating the clip applicator, however, can be used. Shown in Figure 7 is tube or cannula 108 disposed in skin layer 102 and abutting vessel 100. Cannula 108 aids in accessing vessel 100. Arrow E depicts clip applicator 10 being advanced through cannula 108 in a distal direction, towards puncture sight 106. To aid in locating the distal clip applying portion of instrument 10 adjacent the vessel puncture, guide members 94a and 94b receive guide wire 104 therethrough. In Figure 8, the distal portion of cannula 108 is at least partially disposed adjacent vessel 10 and clip applicator 10 has been advanced so that the distal end 14 is disposed in a desired orientation adjacent puncture 106.

[0020] After the distal end of clip applicator 10 is positioned adjacent the wound sight, a first clip is applied from jaws 88 by depressing primary firing button 20 in the direction of Arrow A (Fig. 9). As previously described, when button 20 is completely depressed, button 20 and firing channel 64 are held in the distal position, thereby maintaining jaws 88 in the closed position.

[0021] At this point in the procedure, with reference to Figure 10, guide wire 104 can be removed (Arrow F) from the surgical site. Because jaws 88 are closed and maintain clamping pressure on vessel 100, the orientation of clip applicator 10 and vessel 100 is generally maintained and the guide wire is no longer necessary for alignment. Removal of guide wire 104 allows the vessel to further naturally close. For example, flap 130 in blood vessel 100 is no longer biased away from the vessel wall by guide wire 104 and, therefore, flap 130 can advantageously shift to a position more suitable to closure by jaws 90 and 92. As shown in Fig. 11, second and third clips can now be applied substantially simultaneously by jaws 90 and 92, thereby completing the hole closure procedure, by depressing button 22 as described above. The clips are placed adjacent the first clip applied by jaws 88. Upon release of button 22, both buttons 20 and 22 move proximally, thereby allowing jaws 88, 90 and 92 to open and release the clips and vessel. Subsequent to the application of the clips, clip applicator 10 and cannula 18 can be removed from the surgical site. A topical band-

age or other structure can then be applied to the exterior of skin 102, if desired.

[0022] It is contemplated that the present method and device can be used not only with catheterization procedures but other medical procedures where it is desirable to seal an incision or puncture in patient's blood vessel or artery. By using surgical clips as set forth in the present disclosure, the need to apply pressure to the wound site for an extended period of time is unnecessary. In addition, because the clip or clips are applied externally to the vessel, the danger of foreign matter entering the circulatory system is essentially eliminated.

[0023] The present invention makes the following surgical method possible:

- providing a catheter;
- creating a puncture in a vessel of a patient;
- inserting the catheter through the puncture in the patient's vessel;
- removing at least a portion of the catheter from the patient;
- providing a surgical clip applicator; and
- applying at least one surgical clip to the patient's vessel to at least partially close the vessel puncture through which the catheter was inserted.

[0024] The present invention allows for a surgical method comprising:

- creating a puncture in a vessel of a patient;
- performing a surgical procedure;
- providing a surgical clip applicator; and
- applying at least one surgical clip to the patient's vessel to at least partially close the vessel puncture. In this method, the step of performing a surgical procedure comprises inserting a catheter through the puncture in the patient's vessel.

[0025] It will be understood that various modifications can be made to the embodiments disclosed herein. For example, while the application of three clips has been described as a preferred embodiment, a single clip or any combination of clips can be applied. Such clips can be applied simultaneously or sequentially. It is also contemplated that the order of applying clips and withdrawing the guide wire can be modified. For example, the distal end of the clip applicator can be disposed adjacent the vessel and the guide wire can be removed prior to the application of any clips. Also, it is contemplated that each clip or clips to be applied can be affixed to the vessel prior to removal of the guide wire. Cannula or tube 108 is also optional to the procedure, but is useful for aiding in the insertion and withdrawal of the clip applicator. It is also possible to properly position the clip applicator without the use of a guidewire. However, some structure to aid in locating the distal end of the instrument is preferred. One such structure is a short tube at the distal end of the instrument to receive a guidewire, so that the instrument

may slide along the guidewire, but even a groove or a pair of horns to receive an elongate guidance element might suffice. In addition, the clip applier and method described herein could be modified by one skilled in the art to be used endoscopically. The above description should not be construed as limiting but merely as examples of preferred embodiments. Those skilled in the art will envision other modifications within the scope of the claims appended hereto.

Claims

1. A vascular hole closure apparatus for performing a procedure for closing a catheterization puncture (106) in a blood vessel (100) wherein a guide wire (104) passes extracorporeally through the skin (102), the puncture, and into the blood vessel, the apparatus includes a tubular structure (108) that in use is advanced over the guide wire and positioned near or adjacent the exterior of the blood vessel puncture; the apparatus being **characterized by** a surgical clip applier (10) which contains one or more deformable surgical clips (242), each clip having arms (202, 204) and a bridge (206) connecting the arms, and which can be introduced into the tubular structure (108) and guided thereby to the puncture so that, once the distal end (14) of the clip applier is properly positioned adjacent the puncture, the one or more surgical clips (242) contained within the clip applier (10) are applied to the puncture with the respective arms (202, 204) of the clip engaging tissue adjacent the puncture, and close the puncture by movement towards each other.
2. The apparatus as claimed in claim 1 and including structure to aid in locating the distal end of the clip applier.
3. The apparatus as claimed in claim 2, wherein said locating structure comprises a groove.
4. The apparatus as claimed in claim 2, wherein said structure comprises a pair of horns.
5. The apparatus according to claim 2, wherein said locating structure comprises tubular structure (94) being adapted to receive the guide wire, for sliding the clip applier relative to the guide wire, using the tubular structure as a guide.
6. The apparatus as claimed in any one of the preceding claims, wherein the clip applier includes
 - i) separate first and second clip applier structures (90, 92) for first and second clips (242), and
 - ii) means to maintain engagement between the first clip and the related clip applier structure,

after application of the first clip to tissue, while bodily tissue moves into position adjacent the second clip applier structure, to allow application of the second clip to the positioned tissue.

7. The apparatus as claimed in claim 6, further including release means (48) which releases both first and second clips after application of the second clip.
8. The apparatus according to claims 6 or 7, wherein the second clip applier is adapted to apply at least two surgical clips.
9. The apparatus as claimed in any one of the preceding claims, wherein the clip applier has first and second pairs of jaws (90, 92) and is capable of sequentially applying surgical clips by the steps of:
 - securing a first clip to bodily tissue by closing the first pair of jaws to deform the clip;
 - maintaining the first pair of jaws in the closed position;
 - closing a surgical clip with the second pair of jaws while the first jaws remain in the closed position.
10. The apparatus as claimed in claim 9, including means which cause the first pair of jaws to move to an open position, subsequent to the closure of the second clip.
11. The apparatus as claimed in any one of the preceding claims, the clip applier comprising a handle portion, an intermediate portion and first and second pairs of jaws at a distal end of the intermediate portion, each of the first and second pairs of jaws being adapted to deform at least one surgical clip, wherein the first pair of jaws is actuatable independently of the second pair of jaws.
12. The apparatus according to any one of the preceding claims and comprising at least one push button (20) for application of said surgical clip.
13. The apparatus as claimed in any one of claims 1 to 5, or claim 12 as dependent on any one of claims 1 to 5, which applies just one clip.
14. The apparatus as claimed in claim 2, or any one of claims 3 to 12 as dependent on claim 2, wherein the structure to locate the distal end of the clip applier permits removal of the guide wire before the application of any clips.

Patentansprüche

1. Gefäßloch-Verschlussvorrichtung zum Durchführen

eines Verfahrens zum Schließen eines Kathetereinstichs (106) in einem Blutgefäß (100), wobei ein Führungsdraht (104) außerhalb des Körpers durch die Haut (102), den Einstich und in das Blutgefäß vordringt, wobei die Vorrichtung eine rohrförmige Struktur (108) umfasst, die im Gebrauch über den Führungsdraht vorgeschoben wird und in der Nähe oder neben der Außenseite des Blutgefäßseinstichs positioniert ist; wobei die Vorrichtung **gekennzeichnet ist durch**

eine chirurgische Klammeranbringvorrichtung (10), die eine oder mehrere, verformbare chirurgische Klammern (242) enthält, wobei jede Klammer Arme (202, 204) und eine die Arme verbindende Brücke (206) aufweist, und die in die rohrförmige Struktur (108) eingeführt werden kann und **dadurch** zum Einstich geführt werden kann, sodass sobald das distale Ende (14) der Klammeranbringvorrichtung geeignet neben dem Einstich positioniert ist, die eine oder mehreren chirurgischen Klammern (242), die innerhalb der Klammeranbringvorrichtung (10) enthalten sind, auf den Einstich aufgebracht werden, wobei die jeweiligen Arme (202, 204) der Klammer mit dem Gewebe neben dem Einstich eingreifen und den Einstich **durch** Aufeinanderzu-Bewegung verschließen.

2. Vorrichtung nach Anspruch 1, und eine Struktur umfassend, die dabei hilft, das distale Ende der Klammeranbringvorrichtung zu lokalisieren. 30
3. Vorrichtung nach Anspruch 2, wobei die Lokalisierstruktur eine Nut umfasst.
4. Vorrichtung nach Anspruch 2, wobei die Struktur ein Paar von Hörnern umfasst. 35
5. Vorrichtung nach Anspruch 2, wobei die Lokalisierstruktur eine rohrförmige Struktur (94) umfasst, die geeignet ist, den Führungsdraht aufzunehmen, um die Klammeranbringvorrichtung relativ zum Führungsdraht zu verschieben, wobei die rohrförmige Struktur als Führung verwendet wird. 40
6. Vorrichtung nach einem der voranstehenden Ansprüche, wobei die Klammeranbringvorrichtung umfasst: 45
 - i) getrennte erste und zweite Klammeranbringstrukturen (90, 92) für die erste und zweite Klammer (242), und 50
 - ii) Mittel zur Beibehaltung des Eingriffs zwischen der ersten Klammer und der zugehörigen Klammeranbringstruktur, nachdem die erste Klammer auf das Gewebe aufgebracht wurde, während sich Körpergewebe in die Position neben der zweiten Klammeranbringstruktur bewegt, um das Aufbringen der zweiten Klammer auf das 55

positionierte Gewebe zu erlauben.

7. Vorrichtung nach Anspruch 6, weiter ein Freigabemittel (48) umfassend, das sowohl die erste als auch die zweite Klammer nach Aufbringen der zweiten Klammer freigibt. 5
8. Vorrichtung nach Anspruch 6 oder 7, wobei die zweite Klammeranbringvorrichtung geeignet ist, mindestens zwei chirurgische Klammern anzubringen. 10
9. Vorrichtung nach einem der voranstehenden Ansprüche, wobei die Klammeranbringvorrichtung ein erstes und zweites Paar von Klauen (90, 92) aufweist und in der Lage ist, chirurgische Klammern nacheinander mittels folgender Schritte aufzubringen:
 - Befestigen einer ersten Klammer an Körpergewebe, indem das erste Paar von Klauen geschlossen wird, um die Klammer zu verformen; Halten des ersten Pairs von Klauen in der geschlossenen Position; Schließen einer chirurgischen Klammer mit dem zweiten Paar von Klauen, während die ersten Klauen in der geschlossenen Position bleiben. 15
10. Vorrichtung nach Anspruch 9, Mittel umfassend, die das erste Paar von Klauen veranlassen, sich nach dem Schließen der zweiten Klammer in eine offene Position zu bewegen. 30
11. Vorrichtung nach einem der vorangehenden Ansprüche, wobei die Klammeranbringvorrichtung einen Griffabschnitt, einen mittleren Abschnitt und ein erstes und zweites Paar von Klauen an einem distalen Ende des mittleren Abschnitts umfasst, wobei sowohl das erste als auch das zweite Paar von Klauen geeignet ist, mindestens eine chirurgische Klammer zu verformen, wobei das erste Paar von Klauen unabhängig vom zweiten Paar von Klauen betätigbar ist. 40
12. Vorrichtung nach einem der vorangehenden Ansprüche, und mindestens einen Druckknopf (20) zum Aufbringen der chirurgischen Klammer umfassend. 45
13. Vorrichtung nach einem der Ansprüche 1 bis 5 oder nach Anspruch 12, wenn abhängig von einem der Ansprüche 1 bis 5, die lediglich eine Klammer aufbringt. 50
14. Vorrichtung nach Anspruch 2 oder einem der Ansprüche 3 bis 12 wenn abhängig von Anspruch 2, wobei die Struktur zum Lokalisieren des distalen Endes der Klammeranbringvorrichtung die Entfernung des Führungsdrahts vor Aufbringen jeglicher Klammern erlaubt. 55

Revendications

1. Dispositif de fermeture d'une plaie vasculaire pour exécuter une procédure pour fermer une ponction de cautérisation (106) dans un vaisseau sanguin (100), où un fil de guidage (104) passe extra-corporellement à travers la peau (102), la ponction et dans le vaisseau sanguin, l'appareil comprend une structure tubulaire (108) qui, lors de l'utilisation, est amenée à avancer sur le fil de guidage et est positionnée à proximité ou d'une manière adjacente à l'extérieur de la ponction du vaisseau sanguin; l'appareil étant **caractérisé par** un applicateur de pinces chirurgicales (10) qui contient une ou plusieurs pinces chirurgicales déformables (242), chaque pince ayant des branches (202, 204) et un dos (206) reliant les branches, et qui peut être introduit dans la structure tubulaire (108) et guidé par celle-ci à la ponction de telle sorte que, lorsque l'extrémité distale (14) de l'applicateur de pinces est positionnée correctement d'une manière adjacente à la ponction, une ou plusieurs pinces chirurgicales (242) se trouvent. dans l'applicateur de pinces (10) sont appliquées à la ponction, les branches respectives (202, 204) de la pince s'engageant dans le tissu adjacent à la ponction et ferment la ponction par un mouvement l'une vers l'autre.
 2. Appareil selon la revendication 1 et comprenant une structure pour contribuer à la localisation de l'extrémité distale de l'applicateur de pinces.
 3. Appareil selon la revendication 2, où ladite structure de localisation comprend une rainure.
 4. Appareil selon la revendication 2, où ladite structure comprend une paire de cornes.
 5. Appareil selon la revendication 2, où ladite structure de localisation comprend une structure tubulaire (94) apte à recevoir le fil de guidage, pour le coulissement de l'applicateur de pinces relativement au fil de guidage, en utilisant la structure tubulaire comme un guide.
 6. Appareil selon l'une des revendications précédentes, où l'applicateur de pinces comprend
 - i) des première et seconde structures d'application de pinces séparées (90, 92) pour les première et deuxième pinces (242), et
 - ii) un moyen pour maintenir l'engagement entre la première pince et la structure associée de l'applicateur de pinces, après l'application de la première pince au tissu, pendant que le tissu corporel se met en position pour être adjacent à la deuxième structure d'application de pince, pour permettre l'application de la deuxième pin-
7. Appareil selon la revendication 6, comprenant en outre un moyen de libération (48) qui libère à la fois la première et la seconde pince après l'application de la seconde pince.
8. Appareil selon les revendications 6 ou 7, où le second applicateur de pinces est apte à appliquer au moins deux pinces chirurgicales.
9. Appareil selon l'une des revendications précédentes, où l'applicateur de pinces possède des première et seconde paires de mâchoires (90, 92) et est apte à appliquer séquentiellement les pinces chirurgicales par les étapes consistant à :
 - fixer une première pince au tissu corporel en fermant la première paire de mâchoires pour déformer la pince;
 - maintenir la première paire de mâchoires en position fermée;
 - fermer une pince chirurgicale avec la seconde paire de mâchoires pendant que les première mâchoires restent en position fermée.
10. Appareil selon la revendication 9, incluant des moyens qui amènent la première paire de mâchoires à rejoindre une position ouverte, à la suite de la fermeture de la seconde pince.
11. Appareil selon l'une des revendications précédentes, l'applicateur de pinces comprenant une portion de poignée, une portion intermédiaire et des première et seconde paires de mâchoires à une extrémité distale de la portion intermédiaire, chacune des première et seconde paires de mâchoires étant aptes à déformer au moins une pince chirurgicale, où la première paire de mâchoires est actionnable indépendamment de la seconde paire de mâchoires.
12. Appareil selon l'une des revendications précédentes et comprenant au moins un bouton-poussoir (20) pour l'application de ladite pince chirurgicale.
13. Appareil selon l'une des revendications 1 à 5, ou la revendication 12 dépendant de l'une des revendications 1 à 5, qui applique uniquement une pince.
14. Appareil selon la revendication 2, ou l'une des revendications 3 à 12 dépendant de la revendication 2, où la structure pour localiser l'extrémité distale de l'applicateur de pinces permet le retrait du fil de guidage avant toute application de pince.

ce au tissu positionné.

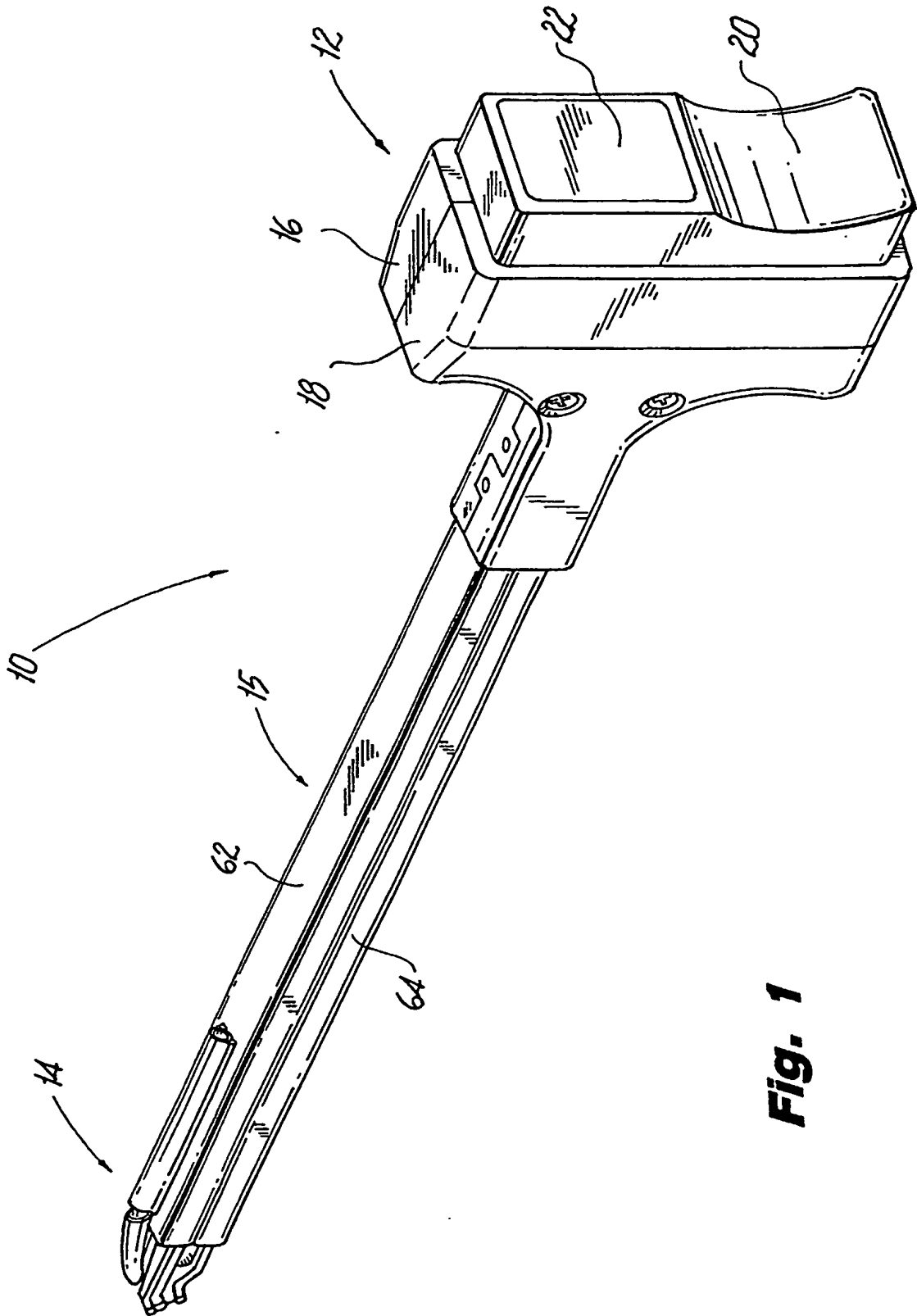

Fig. 1

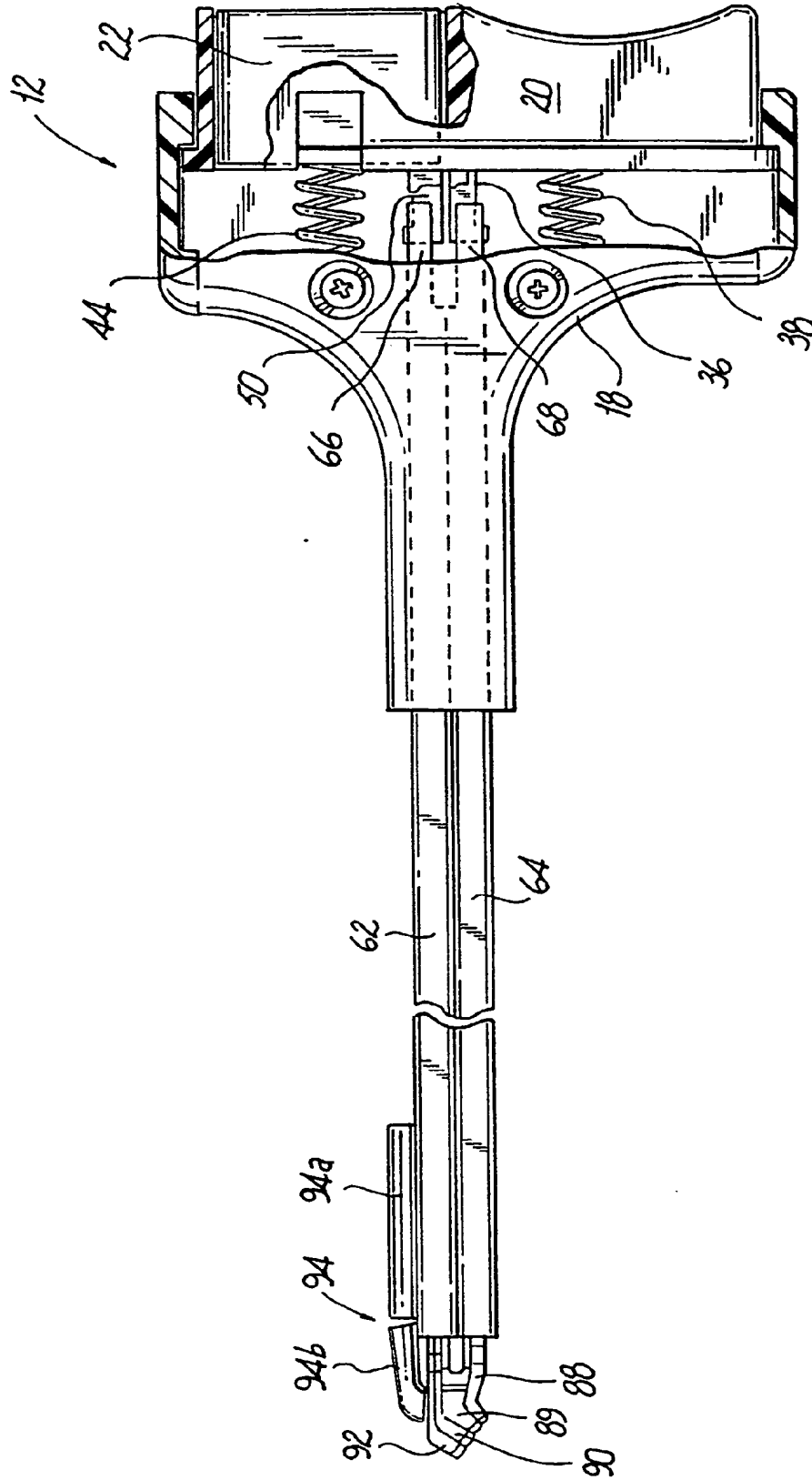

Fig. 2

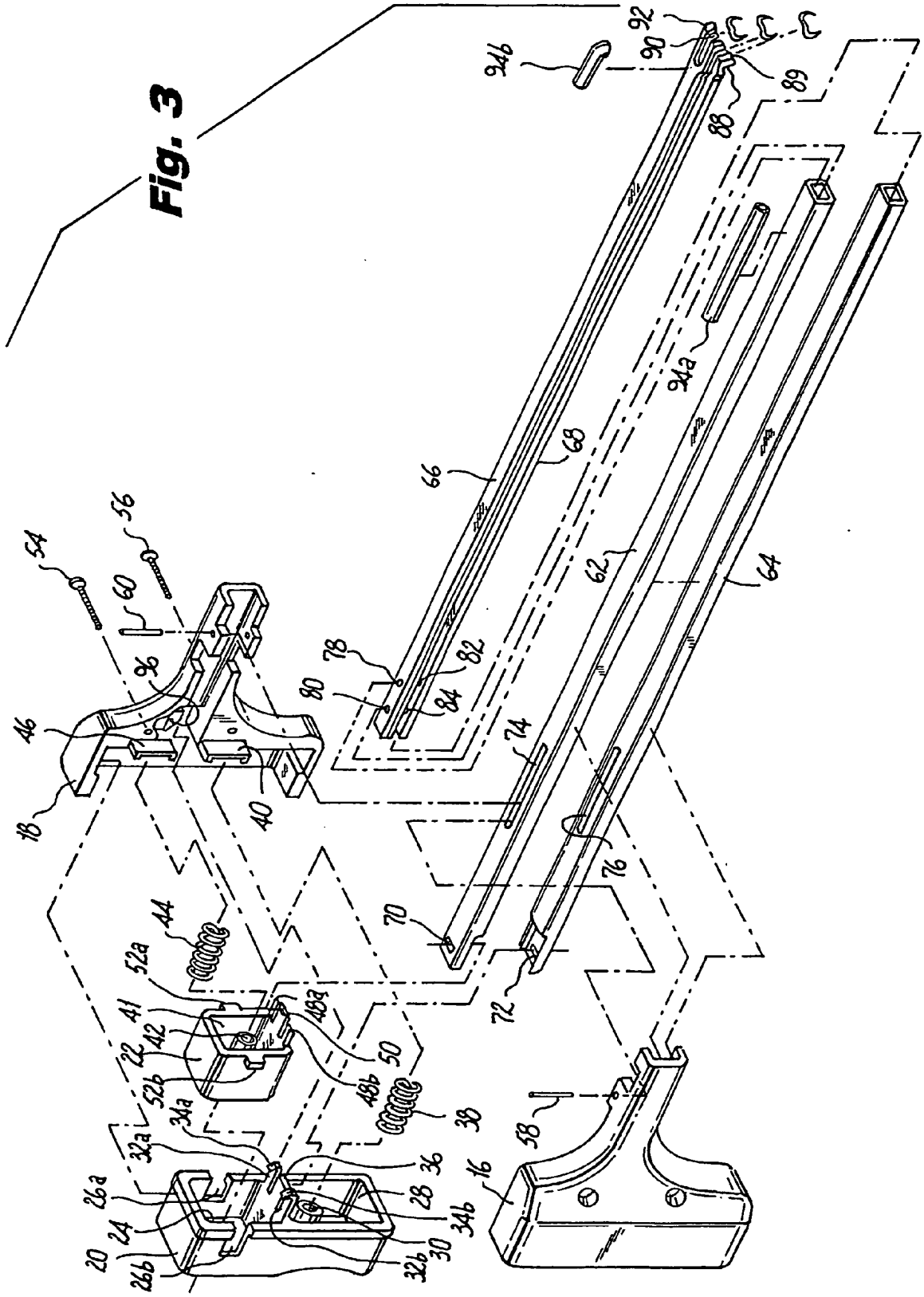

Fig. 3

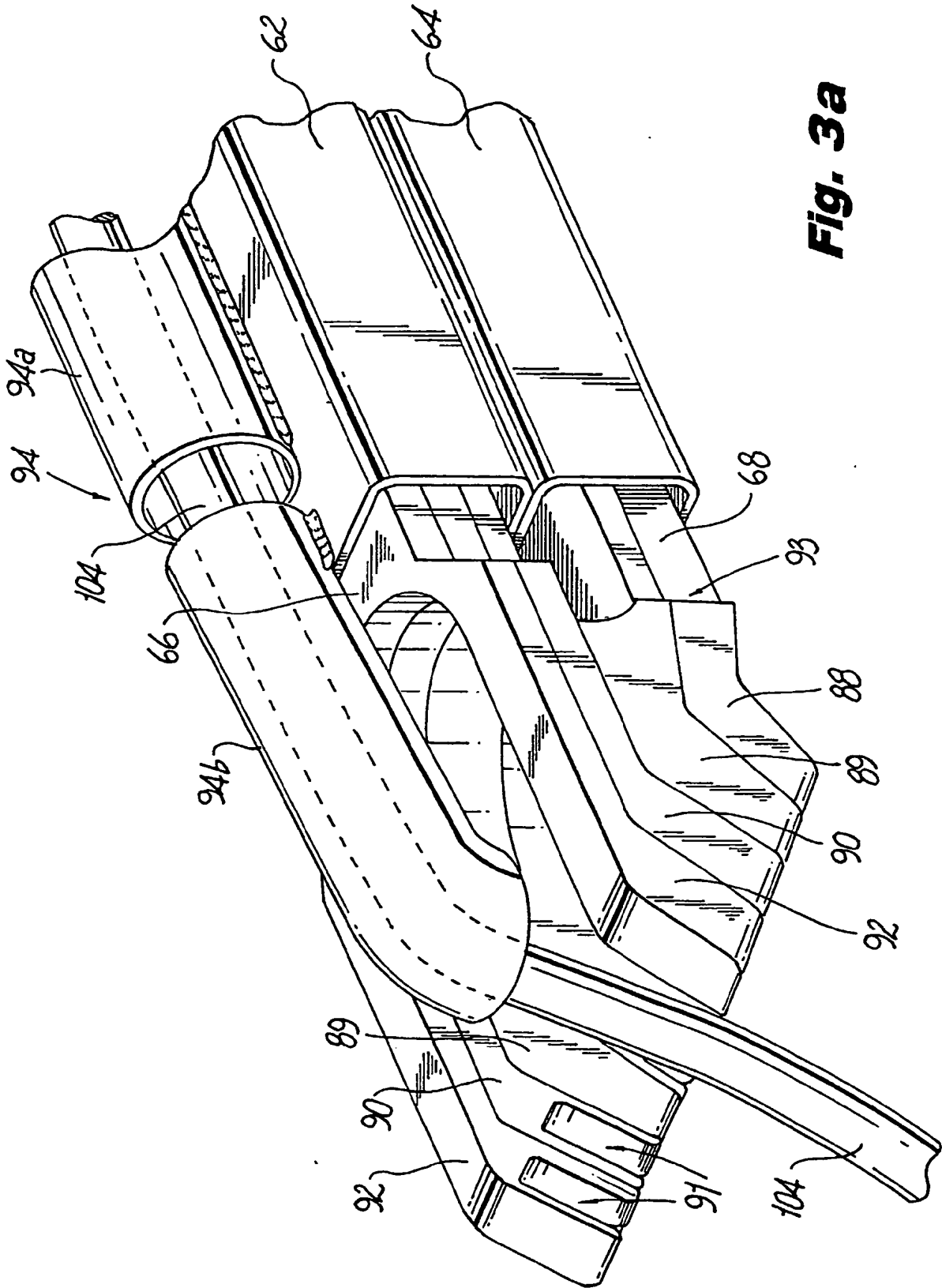

Fig. 3a

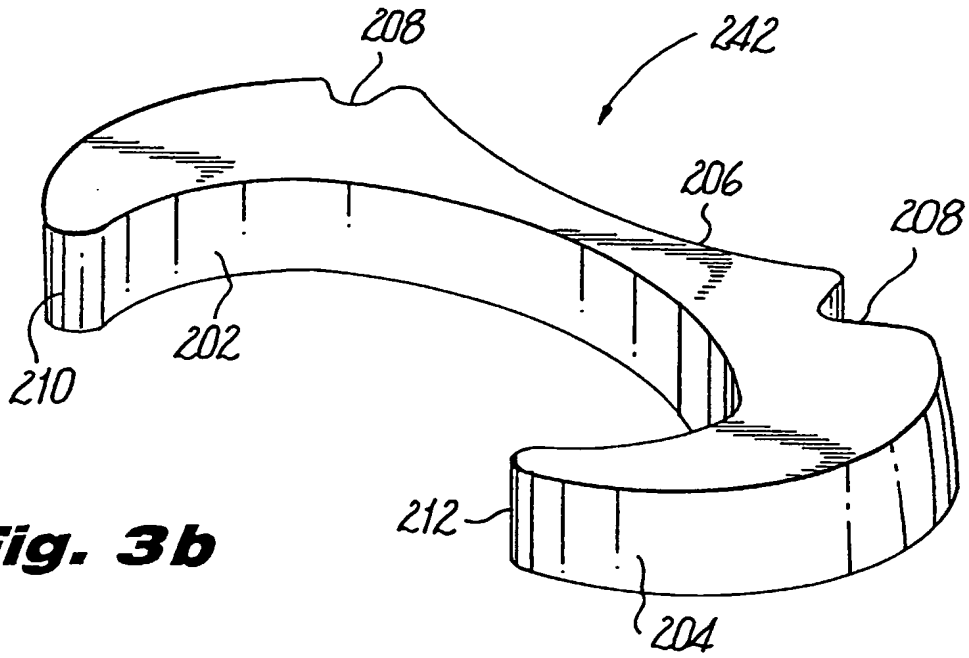

Fig. 3b

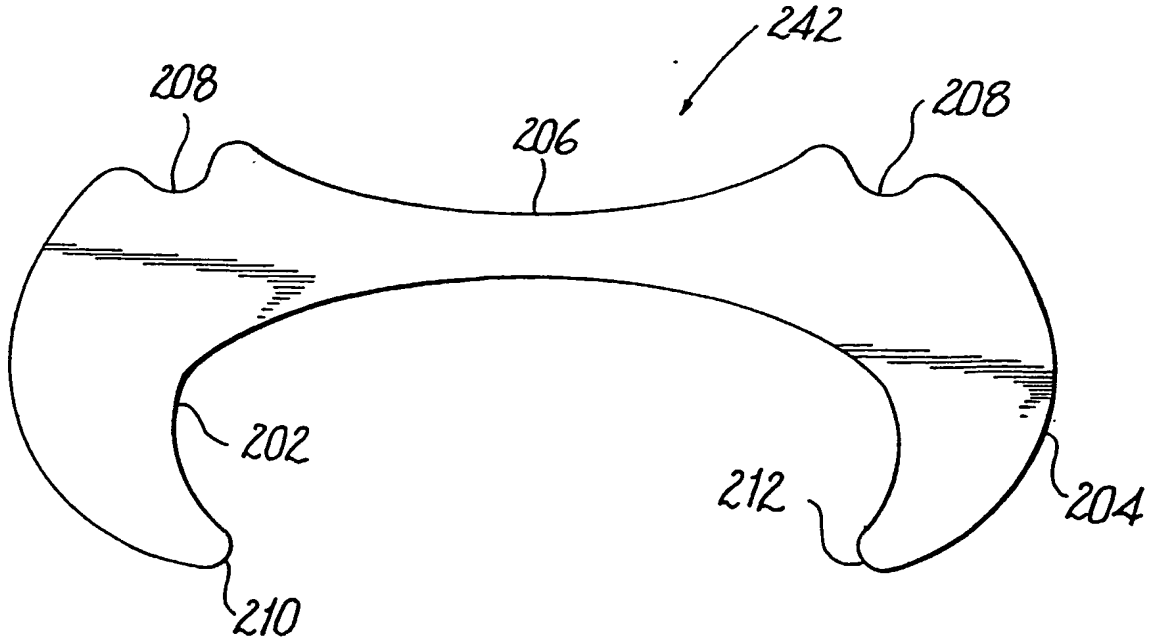

Fig. 3c

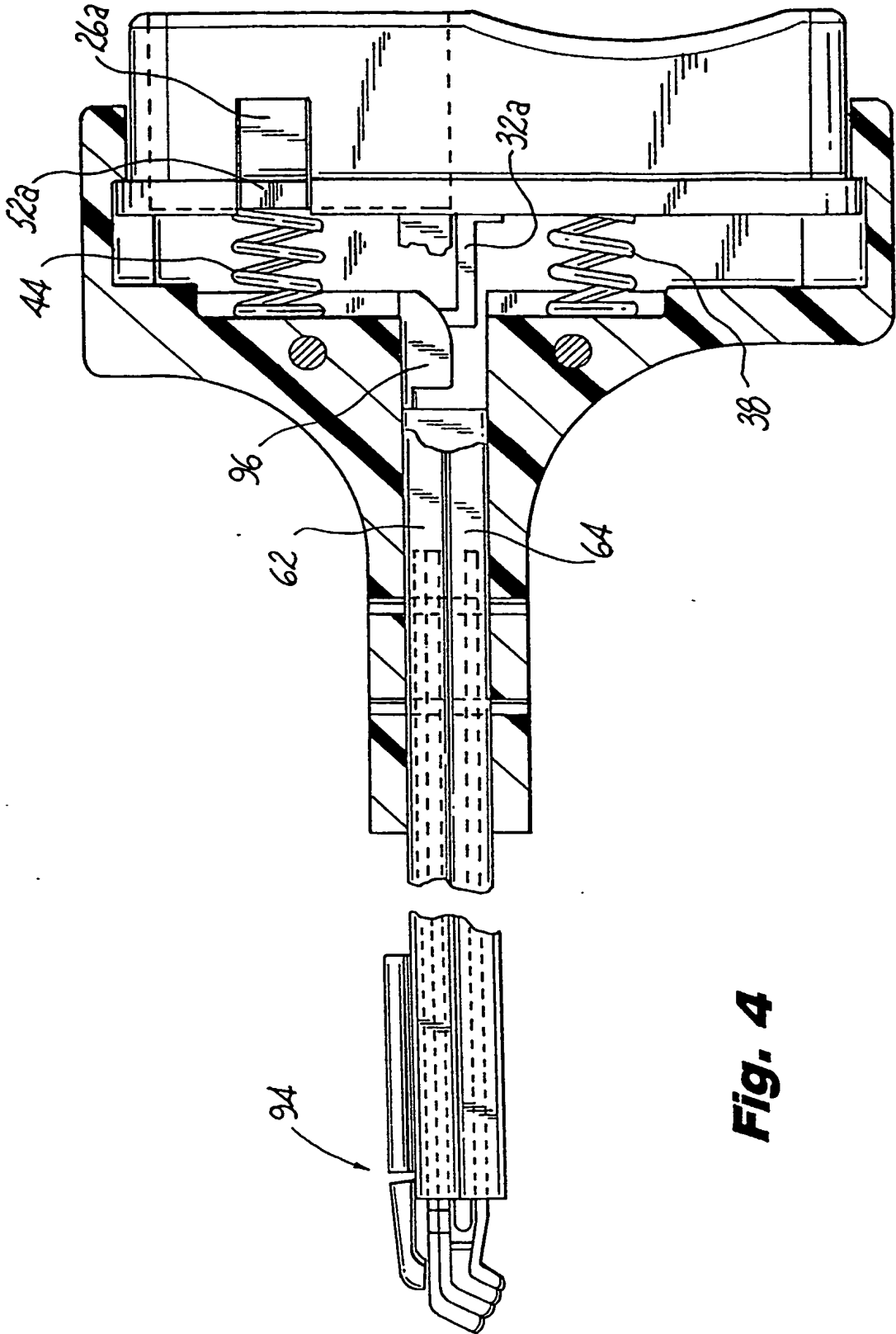

Fig. 4

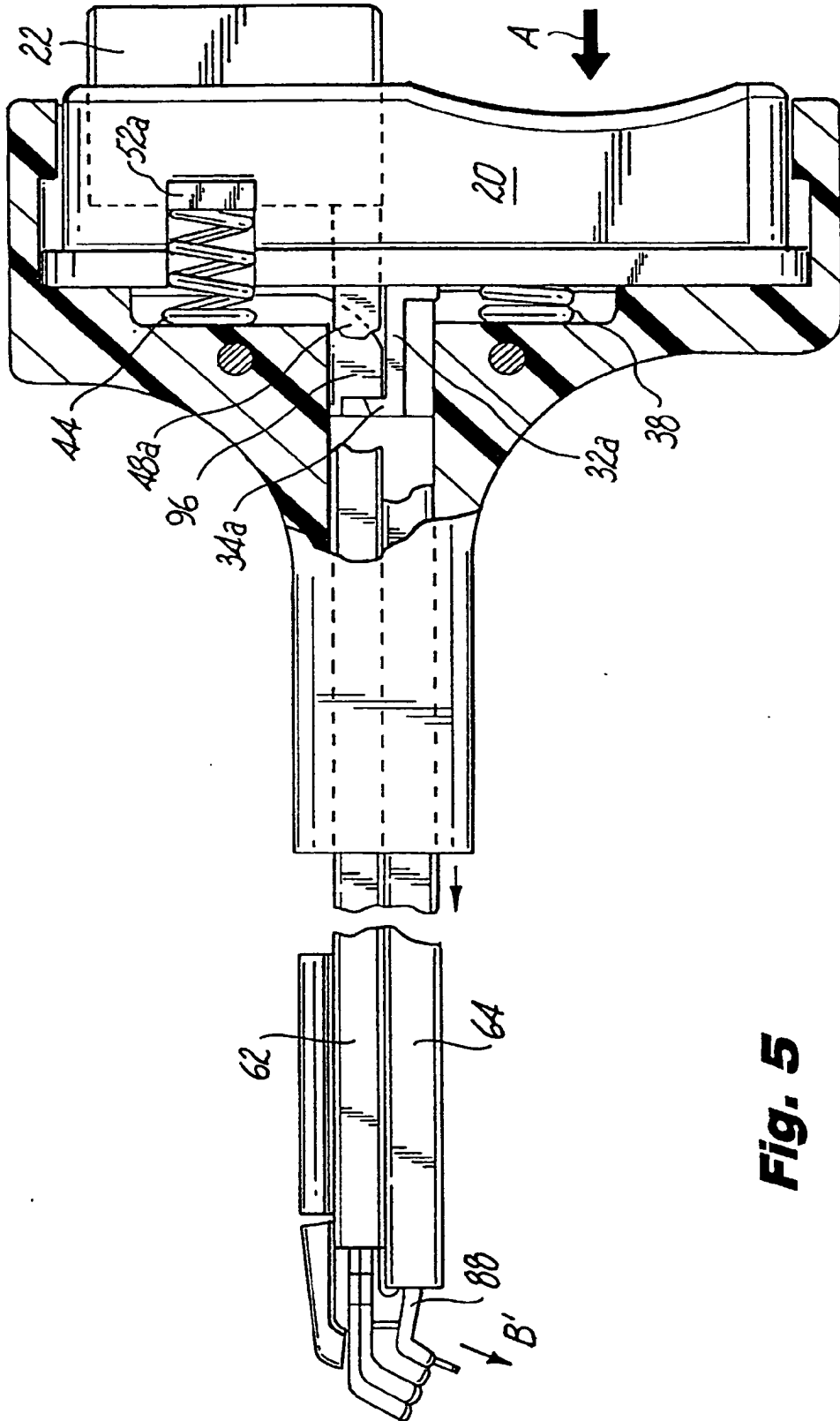

Fig. 5

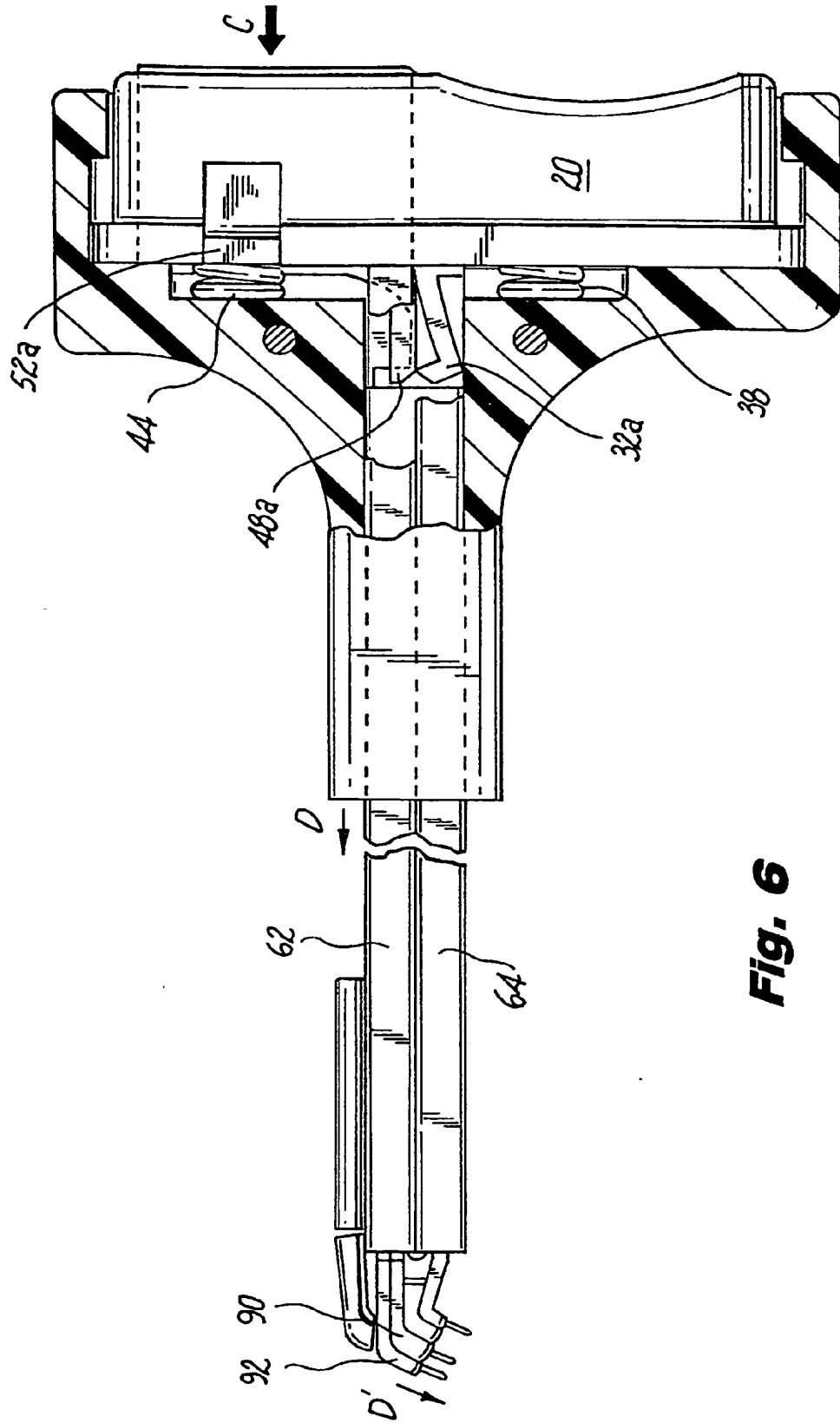
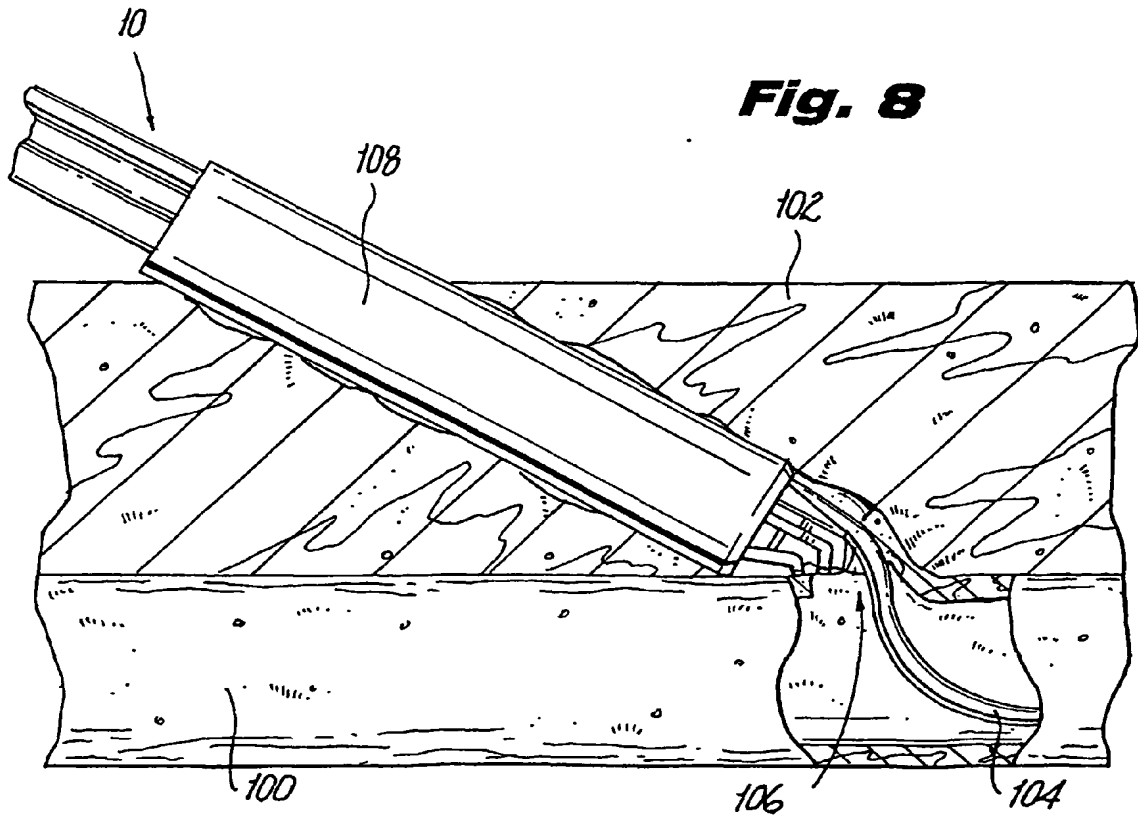
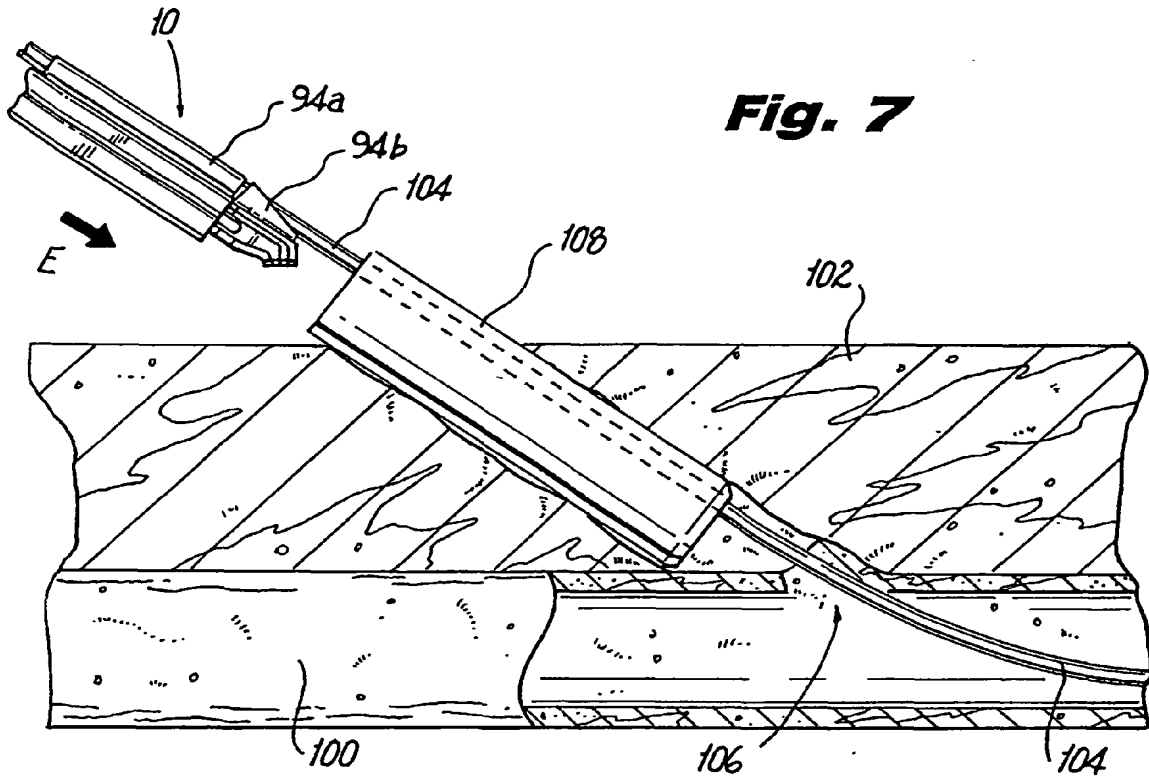

Fig. 6



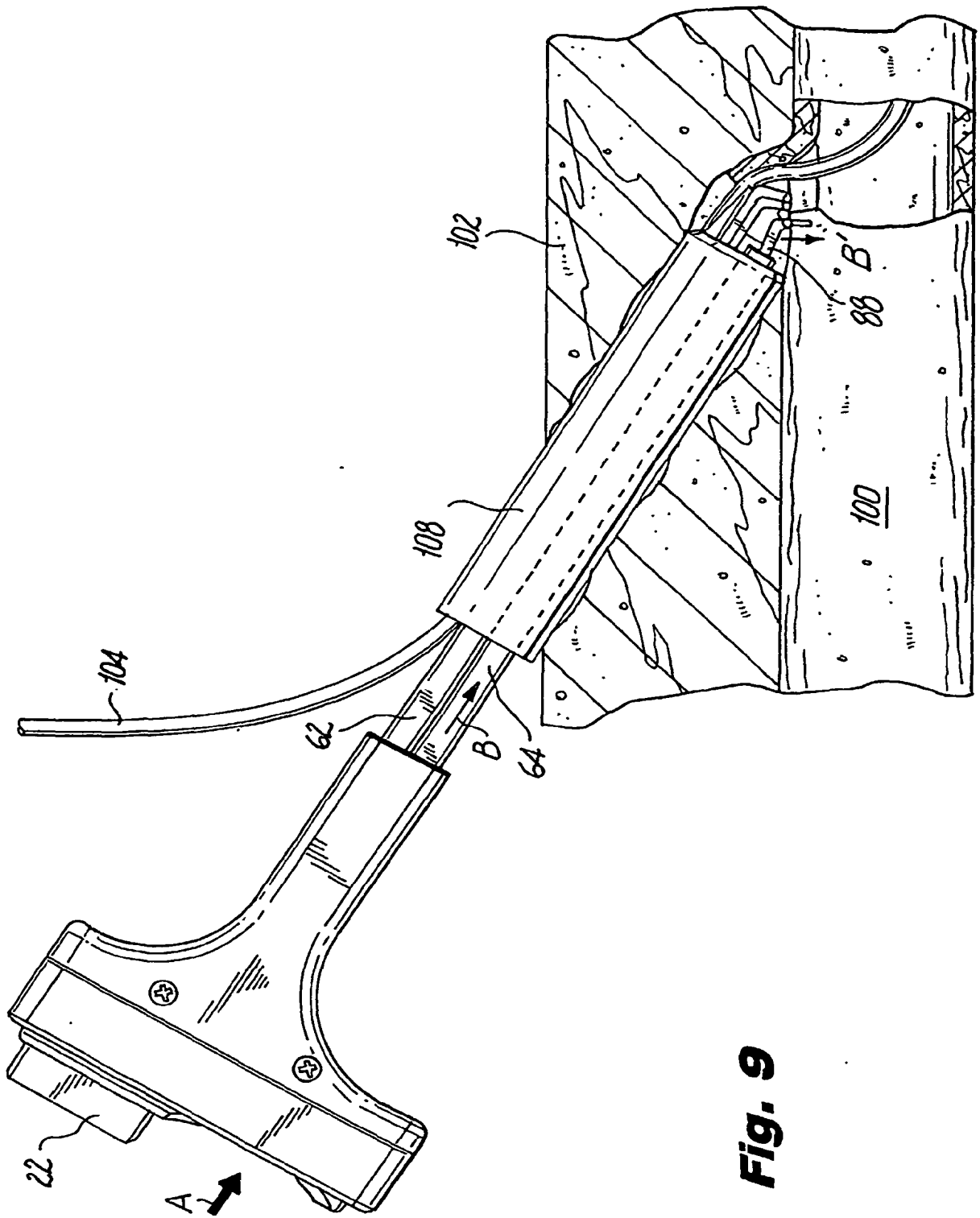

Fig. 9

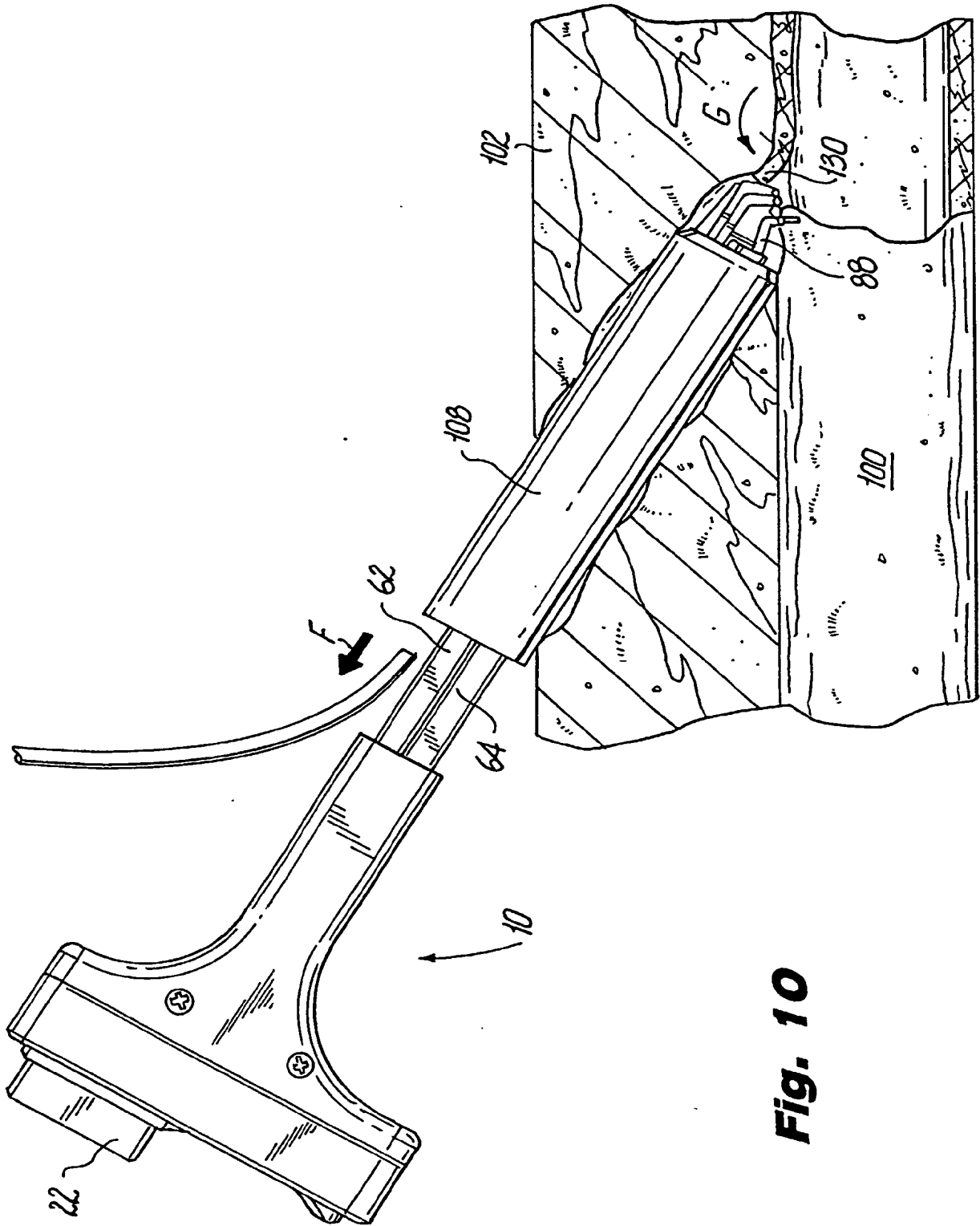

Fig. 10

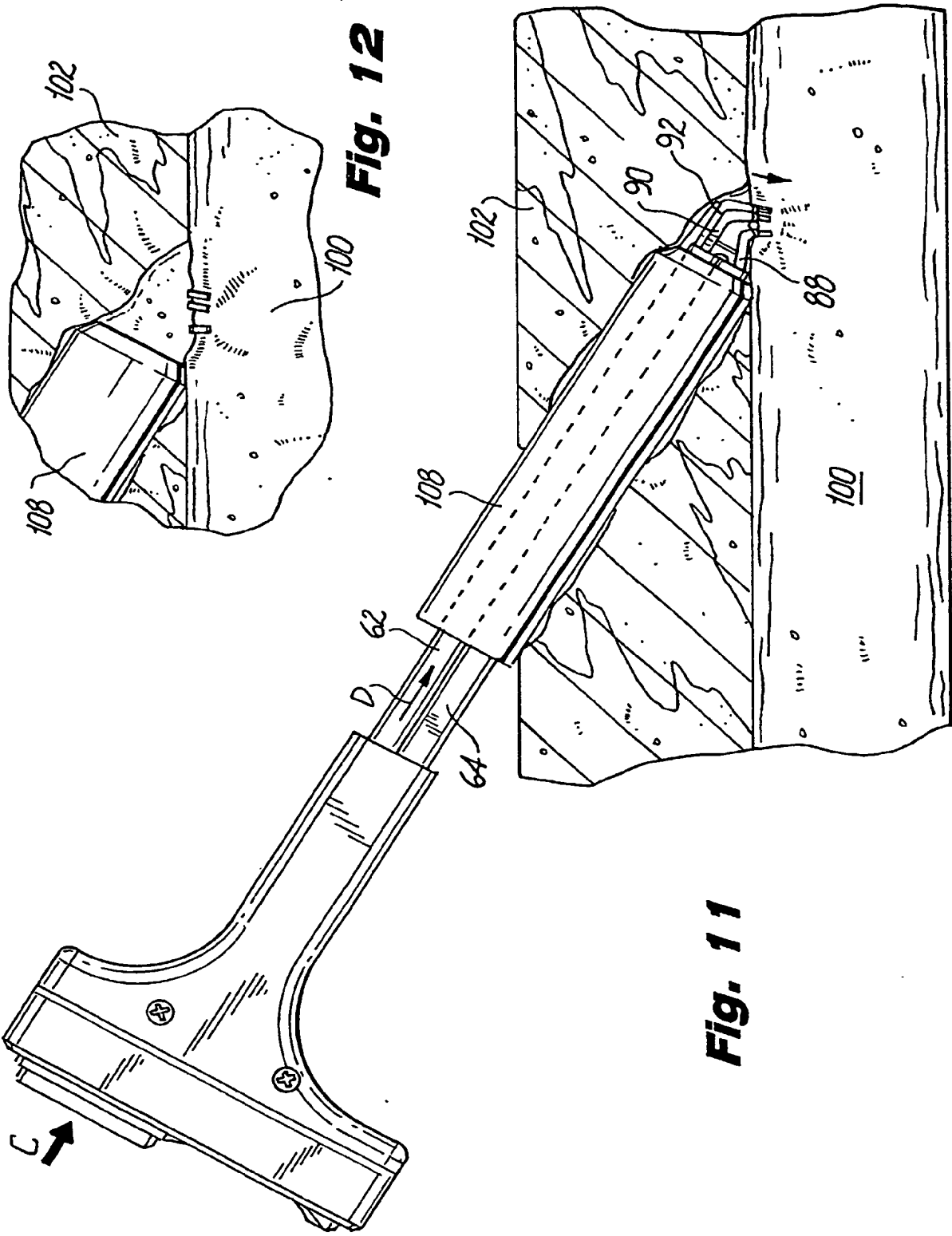

Fig. 12

Fig. 11